



TESTED TOUGH

HD

HD Cottered Triple Strand Chain

(All dimensions listed in inches)

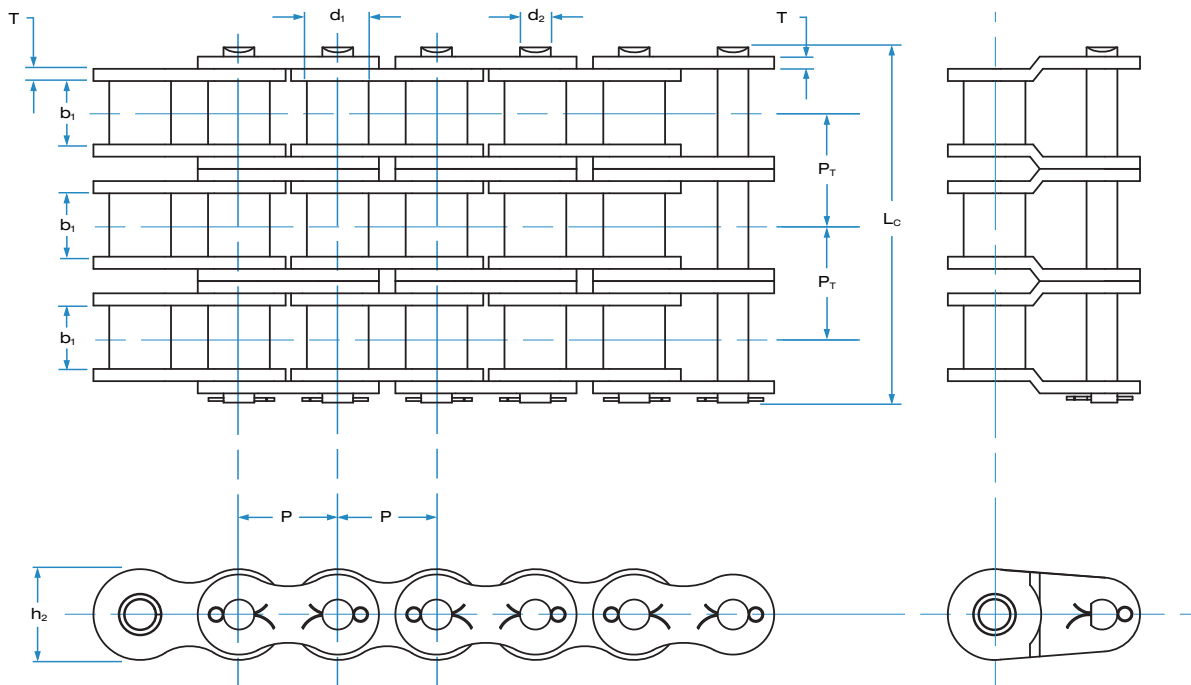

Chain Number	Pitch	Roller Diameter	Width Between Inner Plates	Pin Diameter	Pin Length	Inner Plate Height	Plate Thickness	Transverse Pitch	Min. Ultimate Tensile Strength (lbs)	Average Tensile Strength (lbs)	Max Working Load (lbs)	Weight per Foot (lbs/ft)
	P	d_1 max	b_1 min	d_2 max	L_c max	h_2 max	T max	P_T				
HD50-3 COTT	0.625	0.400	0.375	0.200	2.33	0.59	0.080	0.71	15,136	17,490	3,691	2.1
HD60-3 COTT	0.750	0.469	0.500	0.234	2.91	0.71	0.094	0.90	21,682	24,976	5,088	3.1
HD80-3 COTT	1.000	0.625	0.625	0.312	3.74	0.94	0.125	1.15	38,659	44,602	8,505	5.3
HD100-3 COTT	1.250	0.750	0.750	0.375	4.58	1.18	0.156	1.41	60,341	69,601	13,048	7.9
HD120-3 COTT	1.500	0.875	1.000	0.437	5.72	1.41	0.187	1.79	86,591	98,286	17,518	11.8
HD140-3 COTT	1.750	1.000	1.000	0.500	6.17	1.61	0.219	1.92	117,545	133,379	23,132	14.9
HD160-3 COTT	2.000	1.125	1.250	0.562	7.35	1.88	0.250	2.31	154,636	175,486	30,670	20.2
HD180-3 COTT	2.250	1.406	1.406	0.687	8.28	2.11	0.281	2.59	191,068	221,122	34,391	25.7
HD200-3 COTT	2.500	1.562	1.500	0.781	9.07	2.36	0.312	2.82	241,227	273,772	41,395	32.9
HD240-3 COTT	3.000	1.875	1.875	0.937	10.97	2.85	0.375	3.46	347,932	394,877	57,391	48.1